

Making a wheel puller

You can easily modify a car battery tool

by Will Grovender

FOR AN AVID three-railer, routine locomotive maintenance can be an enjoyable part of the hobby – until it's time to yank the drive wheels off a locomotive and you realize you don't have the right tool for the job. That's when you'll need a wheel puller.

Unfortunately, wheel pullers aren't exactly a staple in many O gaugers' toolboxes. Fortunately, a wheel puller that works on many types of flanged gear wheels can be made quickly and easily from a common battery terminal puller (fig. 1), available at most auto stores. The whole project can take as little as half an hour.

Battery terminal pullers are easy to find and cost only a few dollars each. So if you're not satisfied with the results of the first wheel puller you make, you can make another. In fact, you may find it convenient to make different wheel pullers customized for different drive-wheel assemblies.

In any case, be sure to get a battery terminal puller that has wide clamps to avoid damaging your drive-wheel flanges. My converted puller is only intended for flanged gear wheels, which are thicker and stronger than non-gear wheels and usually have more room between the wheel flange and motor chassis.

Pull start

To begin the conversion, remove the shoe at the end of the threaded bolt by turning the bolt counterclockwise until the shoe pops off. Then keep on unscrewing the bolt until you have completely removed it from the battery puller assembly.

The tip of the threaded bolt must be reduced to a diameter slightly smaller than a locomotive drive wheel's axle. (You can use a spare wheel as a sizing reference.) You'll need a powered grinding wheel with a flat surface, a

small container of water to cool the metal, safety goggles, and maybe a little practice before you begin in earnest.

Before you turn the grinder on, practice holding the bolt parallel to the grinding wheel surface and slowly turning it against the direction of the grinding wheel. Grinding takes no great skill, but it does require patience and a steady hand.

Once you feel ready, turn on the grinder and begin turning the bolt as you gently touch the rod to the grinding wheel $\frac{3}{8}$ of an inch back from the bolt tip. (Fig. 2.) As the tip becomes warm, cool it in the water. Frequently check the diameter of the bolt tip to see if it fits inside the spare wheel (fig. 3), and be careful not to grind off too much at one time. (The metal will grind off faster as the tip becomes smaller, so beware.) Repeat the grinding and cooling process until the tip fits snugly into the spare wheel. When it does, screw the threaded bolt back into the puller assembly.

You can now see if the modified puller properly grips the wheel without your locomotive's motor chassis getting in the way. Place the puller clamps on opposite sides of a gear wheel to check the space between the gear wheel flange and the motor chassis. The puller clamps should fit up against the gear wheel teeth.

If not, grind the clamps until the puller just fits into place. (Fig. 4.) In this manner, you can customize another wheel puller for different locomotives. Be sure the bolt's tip aligns over the center of the wheel.

Wheeling it out

Your wheel puller is now ready for the job. But be forewarned: Locomotive wheels can be pressed on so tight at the factory that they simply will not budge without breaking.

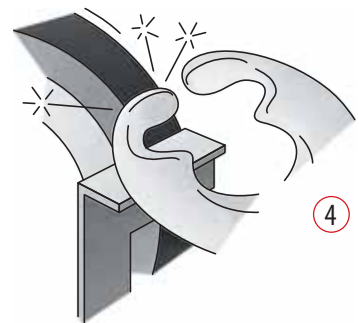
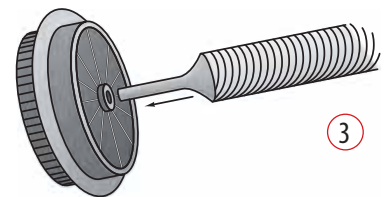
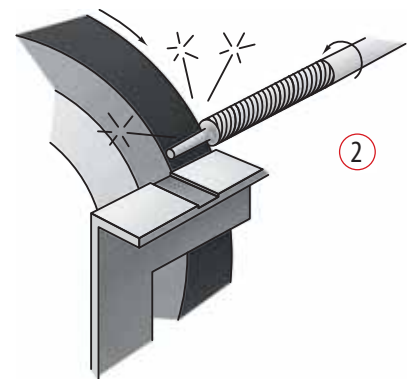
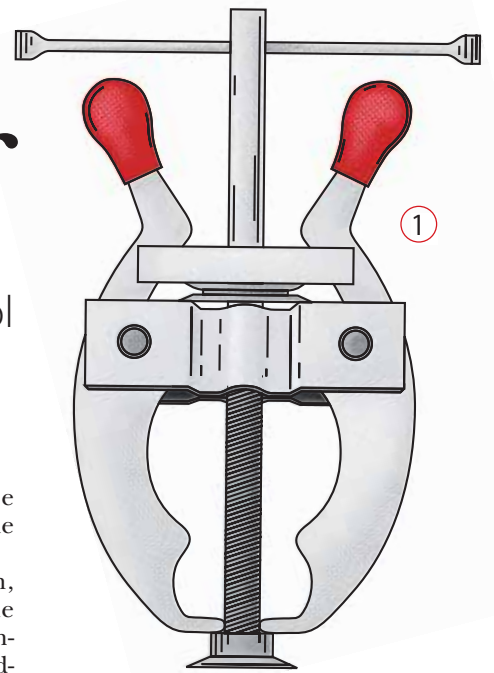

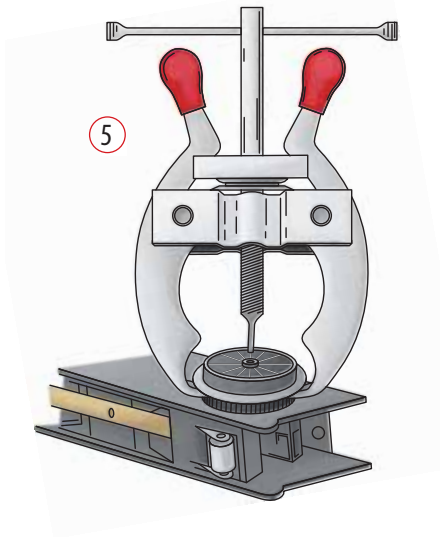

With one hand, make sure the puller clamps are held against the gear wheel teeth. (Fig. 5.) With the other hand, begin to turn the threaded bolt until it comes in contact with the end of the axle. (Fig. 6.) Tighten the wheel puller slowly. The wheel should pop off the axle with only moderate pressure. If it doesn't, remove the wheel puller and try soaking the locomotive wheels in penetrating oil overnight.

Once you have the wheels off and your maintenance work is done, use caution when placing the wheels back on the axles. A simple vise will often suffice, but a wheel press is ideal.

While this wheel puller will work well on a number of Lionel locomotive wheels, you may find it will not fit other manufacturer's wheels. For example, some Marx engines have wheel gear teeth that are flush with the outside edge of the wheel flange, leaving no place to put the wheel puller's clamps.

You'll find this homemade tool useful when you need to disassemble a motor chassis to replace wheel bearings or a contact roller assembly or perform a similar piece of heavy maintenance. If you too enjoy locomotive maintenance, look at this conversion project as an opportunity. A wheel puller will allow you to have more fun by letting you do more types of maintenance. **CTT**

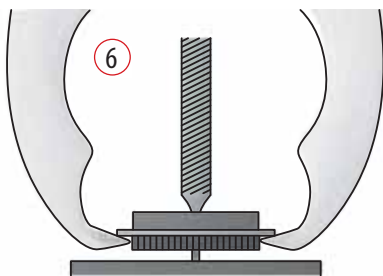

Illustrations by Terri Field